

Top View

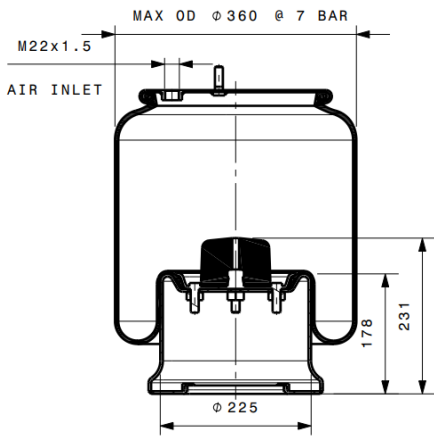

Section View

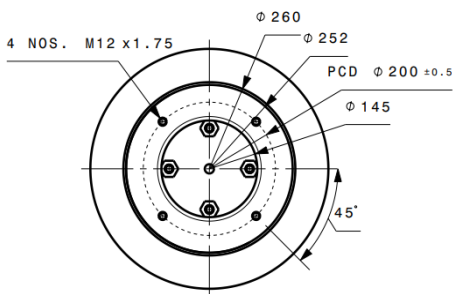

Bottom View

## Technical Data

Part Description: Crimped reversible sleeve complete assembly
Maximum Height: 700mm
Maximum Recommended Height: 680mm
Design Height: 455mm
Minimum Recommended Height: 190 mm
Minimum Height: 185 mm
Bumper Contact Height: ±24mm
Working Stroke: 490mm
Load Capacity @ 7 BAR @ 455mm (±5%): 41.2kN
Maximum OD @ 7 BAR: φ 360mm
Required Space: 385mm
Weight (±0.5kg) : 12.5kg

## Force (kN)

Air Pressure	1 bar	2 bar	3 bar	4 bar	5 bar	6 bar	7 bar	8 bar
600	4.30	6.80	10.50	14.50	18.85	23.45	28.20	33.25
580	4.95	9.00	13.10	17.10	22.10	27.05	32.30	37.65
560	5.40	10.05	14.90	19.90	25.20	30.50	36.00	41.95
540	5.15	10.80	16.25	21.70	27.45	32.95	39.20	45.55
520	5.15	11.00	17.15	23.25	29.15	35.35	41.55	48.10
500	5.20	11.15	17.20	23.55	29.90	36.35	42.90	50.00
480	5.25	10.90	17.00	23.50	29.85	36.60	43.35	50.30
460	4.90	10.75	17.10	23.10	29.65	36.50	43.00	49.65
440	5.15	10.70	17.30	23.40	29.75	36.60	42.90	49.60
420	5.40	11.05	17.20	23.30	29.85	36.40	42.80	49.50
400	5.45	10.90	17.35	23.60	29.65	36.15	42.65	49.50
380	5.20	10.90	17.20	23.45	29.85	36.30	42.70	49.45
360	5.65	11.15	17.20	23.45	29.90	36.10	42.70	49.40
340	5.45	11.60	17.35	23.75	29.75	36.25	42.60	49.45
320	5.75	11.50	17.25	23.60	29.90	36.35	42.90	49.55
300	6.35	12.35	18.25	24.25	30.35	36.80	43.45	50.25
280	7.20	13.15	19.35	25.95	32.20	39.35	45.80	52.75
260	7.85	13.75	20.25	26.95	33.80	41.05	48.15	55.45

## Graph

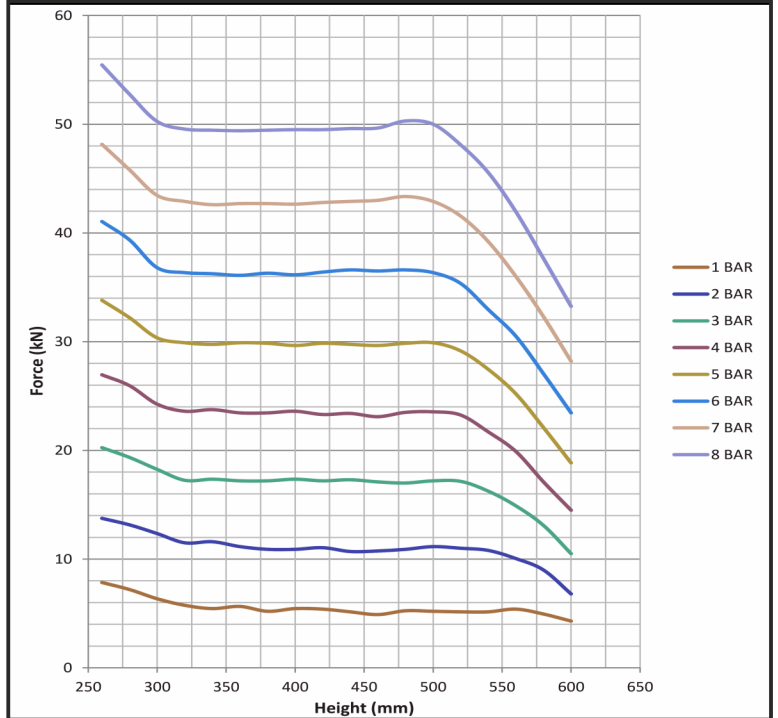

## CROSS REFERENCE

Gibraltar	Firestone	Goodyear	Volvo	Contitech
G19L11-3	1T19L-11	NA	NA	4023 N P 03